

Language learnability and the forms of recursion*

Thomas Roeper and William Snyder

University of Massachusetts at Amherst / University of Connecticut

The usual assumption is that learning is not required for recursive operations, because they are provided by UG. Fundamental operations like Merge are recursive and universal. Yet, grammar-particular choices must be made: in each language, certain forms of recursion are permitted, and others excluded. We advance the following general hypothesis: A primary task of the language-learner is to identify recursive (hence productive) grammatical processes. Different types of recursion define different acquisitional stages, and may also be distinguished in parsing and neurological computation. A case study of root compounding is presented, with reference to English, Swedish, and French.

Introduction

Recursion has been recognized as a fundamental property of human language throughout the history of Generative Grammar. Indeed, in a recent article, Hauser, Chomsky, and Fitch (2002) argue that recursion is what distinguishes human language from the communication systems of nonhuman animals. In this paper we take up the following question: What is the role of recursion in children's acquisition of language?

Our starting point is the fact that across different languages, the precise set of recursive operations that are available actually varies. Hence, questions of language learnability arise immediately. How does the child know what is recursive and what is not? We begin by demonstrating variation in the recursive operations available for complex word formation; our remarks are stated in terms of the Abstract Clitic Hypothesis of Keyser & Roeper (1992).¹ We then turn to questions of language learnability, and argue for the following proposal: Explicit evidence of recursion, in the form of self-embedded structures, plays a central role in language acquisition.

1. The Abstract Clitic Hypothesis

Endocentric compounding is a domain where recursion can take several different forms.² In this section we set out three such forms, using the framework of Keyser & Roeper (1992). We distinguish between root compounds with a monomorphemic modifier (1a), root compounds with a branching modifier (1b), and synthetic compounds (1c). All three compound-types freely permit a constituent (such as an N) to be contained within a larger constituent of the same type. In subsequent sections we will see that the grammatical availability of these different compound-types is subject to cross-linguistic variation.

- (1) a. [restaurant_N [coffee_N cup_N]_N]_N
 b. [[gourmet_N coffee_N]_N cup_N]_N
 c. [[pen_N hold_V] -er_N]_N

Moreover, the availability of recursive root compounding, as in (1a) or (1b), has important consequences for sentence-level syntax. Keyser and Roeper (1992) have presented detailed arguments from English for a close grammatical relationship among phenomena including resultatives (*hammer the metal flat*), particles (*lift the box up*), and compounding. Snyder (1995, 2001) has similarly argued, on comparative and acquisitional grounds, that the operation of endocentric root compounding is a necessity, in order for a language to permit certain complex predicates such as particle constructions and resultatives: Many of the world's languages disallow root compounding as a grammatical operation, and such languages systematically lack the (Germanic-style) particle and resultative constructions.³ Similarly, for any given child acquiring English, the point when V-NP-particle constructions begin to appear in the child's speech is consistently the same as the point when novel N-N compounds begin to appear ($r = .98$, $t(8) = 12.9$, $p < .001$).⁴ We will return to these issues below. For the moment, however, it is useful to point out that Keyser and Roeper's approach will permit us to make a direct connection between compounding and complex predicates.⁵

Following Keyser & Roeper, we assume the following derivation for an English root compound such as *coffee cup*:

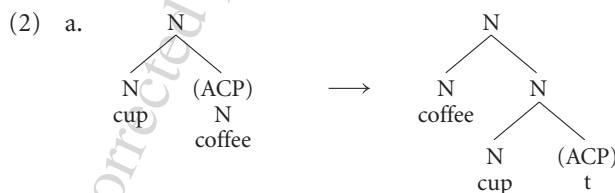

Here we assume that in English, each of the lexical categories (N, V, A, P) can have the Abstract Clitic Position (ACP) as its complement.⁶ This is a significant but

natural generalization of the ACP across categories. Such a claim is theoretically welcome inasmuch as it suggests, as does derivational morphology, that grammatical generalizations should not be sensitive to node labels. In (2a), the modifier *coffee* is first introduced into the ACP, and then must move and adjoin to the left of *cup*.⁷

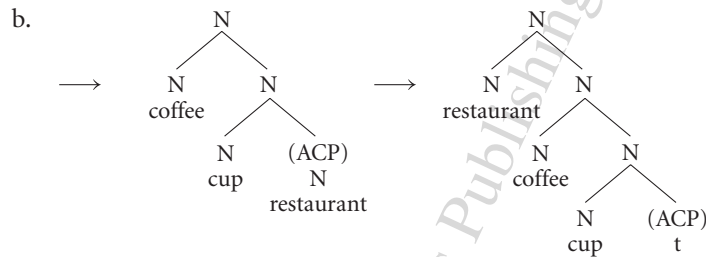

As in Keyser & Roeper, we assume that a (non-argument) trace left in the ACP can be deleted, and that the ACP can then be used to introduce another modifier.⁸ Thus, in (2b) we extend the derivation in (2a) to form the compound *restaurant coffee cup*, or ‘coffee cup of the kind associated with restaurants’.

A second type of root compound can be formed in English by inserting a compound into the ACP. Thus, in (3a, b) we derive [*gourmet coffee*] *cup*.

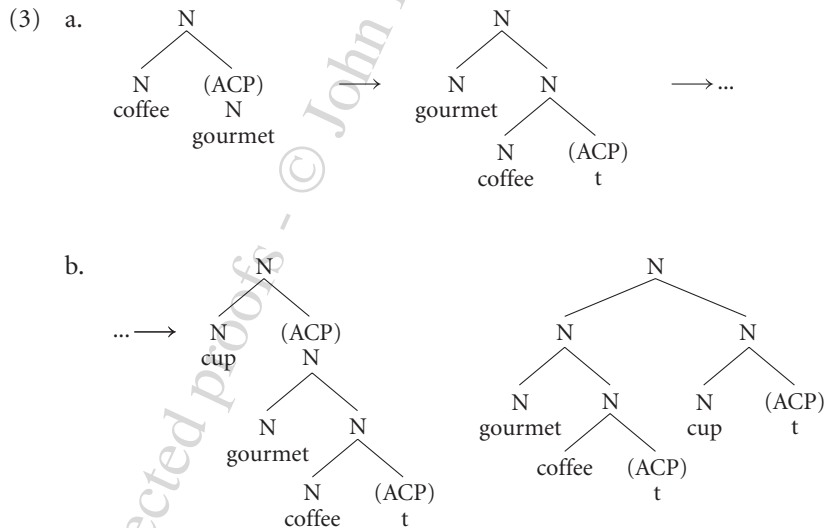

In (3a) we first create the compound *gourmet coffee*. In (3b) we insert the result into the ACP of the N *cup*, to obtain *gourmet coffee cup*, or ‘cup of the kind associated with gourmet coffees’.

One final type of compounding will be relevant for our discussion: synthetic compounding, as in *pen-holder*, or 'device that holds pens'. The derivation we assume for this example is illustrated in (4).

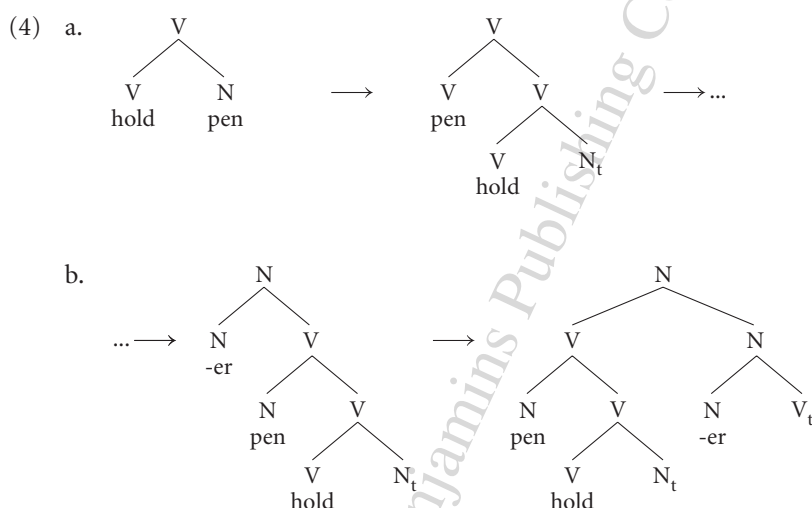

In (4a) we first derive the complex V *pen-hold*. The N *pen* is the complement and logical object of the V *hold*. Then, the compound-formation rule applies to move and adjoin *pen* to the left of *hold*. The trace left by *pen* is an argument trace; following Keyser & Roeper, we assume that this trace is undeletable. In (4b) the resulting complex V is inserted as the complement to the nominal suffix *-er*. Once again, the compound-formation rule applies, and we obtain the surface form *pen-holder*.⁹

In contrast to Keyser & Roeper, we will assume that no ACP is involved in (4). We take the ACP to be associated specifically with modifiers, rather than arguments. In (4) the V *hold* takes the N *pen* as an argument. Likewise, the suffix *-er* takes complex V *pen-hold* as its argument. Thus, the ACP plays no role.¹⁰

2. Cross-linguistic variation: Swedish

Swedish differs from English in the following crucial respect: In Swedish, a branching constituent cannot be inserted into the ACP. As a result, root compounds are strictly right-branching. Consider the examples in (5).

- (5) a. barn [bok klub] 'child [book club], or 'book club for children'
 b. *[barn bok] klub '[child book] club, or 'club for (collectors of) children's books'

- c. [barn bok]-s klub' [child book]'s club', or 'club for (collectors of) children's books'

In (5a), *bok* 'book' modifies *klub* 'club', and *barn* 'child' in turn modifies the entire compound *bok klub*. The compound *barn bok* 'child book', however, cannot modify the N *klub* in (5b). To obtain this reading, the infix *-s* must be used, as in (5c).

The derivation for (5a) is illustrated in (6).

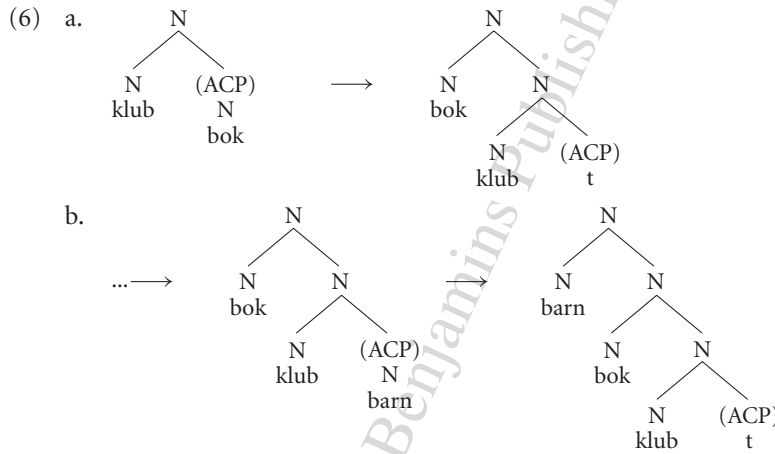

Precisely as in (2a, b), the ACP is first used to introduce the simplex modifier *bok* in (6a). The trace of *bok* is deleted, and the ACP is used again, to introduce the simplex modifier *barn* in (6b).

The (disallowed) derivation for the form in (5b) is illustrated in (7).

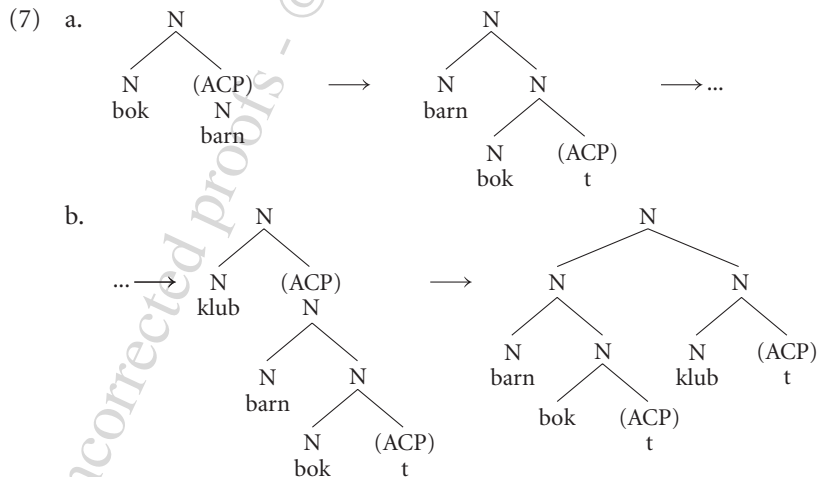

pen is an argument of *hold*, and the complex V *pen-hold* is an argument of the nominal suffix *-er*. The ACP is never involved in predicate-argument relations, but only in relations of modification.¹²

In our approach, the complex V *pen-hold* (or its Swedish equivalent *pen-hål*, in (9a) is an example of a branching constituent hosted in the left branch of a complex word, and thus supports our contention that the constraint operative in Swedish is specifically tied to the ACP. A skeptic might object, however, that the constituency of this word could be *pen-[hold-er]* instead of *[pen-hold]-er*.¹³ To answer this concern, we point to the more complex example in (9b), which is also grammatical in Swedish. Whatever the hierarchical structure of *pen+hål+ar(e)* is, there can be little doubt that it is morphologically complex. The fact that this complex form can itself appear in the left branch of the larger compound *[pen+hål+ar]+hål+are* shows quite clearly that the constraint on branching constituents in Swedish compounds applies only to those modifiers that pass through the ACP.

3. Cross-linguistic variation: French

French contrasts with both Swedish and English in that novel endocentric, root compounds cannot be created at will (as discussed in detail by Bauer 1978; cf. also Di Sciullo & Williams 1987:83). While numerous frozen examples exist in the French lexicon (e.g. *homme grenouille* ‘underwater diver’, lit. ‘man frog’), creating a new endocentric, root compound is comparable to inventing a novel morpheme; its intended meaning must be explained to the listener.

On our account, French differs from English and Swedish in that it altogether lacks the ACP. As a consequence, a bare root cannot automatically enter into a modification relation with another root, to form an endocentric compound. Where endocentric root compounding is an automatic, syntactic process in Germanic, it is only a pattern for conscious word-coinage in French.

In contrast to endocentric root compounding, complex word-formation with closed-class, bound morphemes is fully productive in French. Representative examples appear in (10).

- (10) a. *l'achet+eur* ‘the purchas+er’ (masc.)
 b. *la vend+euse* ‘the sell+er’ (fem.)

The forms in (10) are lexicalized, but the suffixes *-eur* and *-euse* can be applied quite generally to create an agent or instrument nominal from an existing V.¹⁴ Given that the ACP's role lies in general modification relations, not predicate-argument relations of the kind found with derivational suffixes, the latter are unaffected by the absence of the ACP in French.¹⁵

4. Learnability and recursion

The points of cross-linguistic variation encountered above can be stated in parametric terms, as follows:

- (11) The language {does, does not} permit the ACP as the complement to a lexical category.
(Does: English, Swedish; Does not: French)
- (12) The language {does, does not} permit branching constituents to occupy the ACP.
(Does: English; Does not: Swedish; N/A: French)

The point of variation in (12) perhaps reflects a much more general property of human language, which we can state as follows:

- (13) Recursion Constraint: The output of a given operation (such as endocentric root compounding) cannot serve as the input to the same operation.

The Recursion Constraint would then apply everywhere, except when the child's linguistic input provides evidence to the contrary. The constraint makes predictions far beyond root compounding. As a putative deep principle of grammar, it offers a perspective from which to examine all recursive structures. Accordingly, it serves to define a *set* of narrow-UG parameters, to be evaluated through examination of a wide variety of recursive structures.

Returning to the more narrowly stated parameters in (11) and (12), the first question is how the learner can set these parameters correctly, using evidence available from child-directed speech. The existence of numerous lexical compounds (such as *revue mode*, literally 'magazine fashion', for 'fashion magazine') in French means that the simple presence of endocentric root compounds in the input is not a reliable indicator that the language takes the positive setting of (11). Namiki (1994), however, notes that *recursive* compounds (that is, endocentric root compounds properly containing another such compound) are extremely rare in languages of the French type. Further, Roeper, Snyder, and Hiramatsu (2002) have shown that recursive root compounds such as *Christmas tree cookie* and *peanut butter sandwich* are well-represented in English samples of child-directed speech in the CHILDES database MacWhinney (2000).

Given that recursive lexical compounds in French are both few in number and low in frequency of use (the one clear example of which we are aware is *gâteau forêt-noire* 'black-forest cake'), we retain the learnability account of Roeper et al. (2002) for the parameter in (11). Significantly, the child is listening for a self-embedded structure (an endocentric root compound *within* an endocentric root compound), and only if she encounters such evidence for *recursive* application of

the compounding operation, will she conclude that endocentric root compounding is among the grammatical operations available in her language. Without clear evidence of recursion, individual examples of root compounds will simply be stored in the lexicon as isolated cases.

Learnability of the setting for the parameter in (12) can likewise be accomplished by having the child listen for a particular self-embedded structure. This time, the relevant evidence will come from an endocentric root compound containing another such compound as the *modifier*. Again, the samples of child-directed speech examined by Roeper et al. (2002) indicate that such forms are well-attested (consider once again *[[Christmas tree] cookie]* and *[[peanut butter] sandwich]*, for example).

Returning to Hauser, Chomsky, and Fitch's (2002) proposal that recursion is the defining characteristic of the human faculty of language, narrowly construed (the "FLN"), we advance the following strong claims:

- (14) Parametric variation in the FLN amounts to variation in the set of (potentially) recursive operations that are available in each language.
- (15) Children's acquisition of grammar is based on their finding clear evidence that particular grammatical operations have applied recursively.

In present terms, the availability of the ACP, in (11), determines whether endocentric root compounding is available to the language as a potentially recursive, grammatical operation. Likewise, the possibility of inserting a branching constituent into the ACP, in (12), determines whether the left-branching form of recursive root compounding is grammatically available to the language. In both cases, clear evidence to the learner will come from recursive compounds in the input.

One may ask whether a parameter such as (11) constitutes a "global" parameter of the FLN, with widespread consequences for the shape of the language. We submit that it does. As argued in Roeper et al. (2002), the availability of the ACP not only gives rise to recursive root compounding, but is also a prerequisite for complex predicates such as V-NP-Particle constructions and transitive resultatives. The acquisitional evidence in Snyder (1995, 2001) also supports a close connection to English double-object dative constructions (*give Mary the book*) and *make*-causatives (*make John buy the book*). The detailed investigation of English in Keyser & Roeper (1992) indicates further connections, to bare-V/N idioms (*pay attention*), middles (*This book reads easily*), and null-P constructions (*jump (over) the fence*), for example. Hence, the syntactic effects of the parameter in (11) are indeed widespread.^{16,17}

A further question is whether the trigger for a parameter such as (11) is *necessarily* an instance of recursion. An alternative, in the particular case of (11), could be hearing an example of a V-NP-particle construction, for example. While there

are non-recursive triggers available for (11), this turns out not always to be the case. Consider the example of the Saxon genitive in German, as illustrated in (16).

(16) Maria-s Auto ‘Maria’s car’

The morpheme *-s* in (16) serves to mark possession, and at first glance appears comparable to the English possessive marker *-’s*. An important difference, however, is that the English possessive is potentially recursive (17a), while the Saxon genitive is not (17b).

(17) a. [John-’s car]-’s motor
b. *[Hans-ens Auto]-s Motor

The English possessive has a grammatical basis in the phrase structure (the *-’s* is plausibly a D^0), while the Saxon genitive in German is lexical in nature – not formed in the syntax. Crucially, the child acquiring German must avoid misanalyzing the Saxon genitive as an English-like possessive. As far as we are aware, the only way the child can correctly decide whether the *-s* is part of the FLN (as in English) is by waiting for a recursive form, as in (17). In the absence of such evidence, the child will treat the *-s* as lexical, rather than syntactic.¹⁸

What, then, are the forms of recursion that are subject to cross-linguistic variation? They include at least the following: self-embedding, iterative, and scopal recursion. The first type, self-embedding recursion, refers to cases of a structural constituent embedded within a larger constituent of the same type. In addition to endocentric root compounding (with either monomorphemic or polymorphemic modifiers), the X-bar structure of phrase-level syntax belongs to this category. Choices to be made will include setting the X-bar parameters themselves (for example, whether a head precedes or follows its complement), and also deciding whether particular forms (such as the Germanic *-s* suffix) are to be handled syntactically or lexically.

By “iterative” recursion, we mean cases such as *very, very, [...] happy*, where a lexical item is repeated for emphasis; relative-clause sequences such as *This is the cat [that ate the rat [that ran out ...]*; and coordination of (arbitrary numbers of) sentences with conjunctions like *and* and *or*. In all these cases, the relevant grammatical operations can be (and usually are) expressed by recursive rules, but the result is what computer scientists call “tail recursion” – a type of recursion for which simple iteration is a computationally more efficient substitute (compare “This is a cat, and the cat ate a rat, and the rat ran out...”). Finally, by “scopal” recursion we mean cases such as variable binding and negative polarity, naturally described in terms of the *c*-command relation. This relation is formally equivalent to the propagation of information downward, recursively, through a tree.

In summary, points of cross-linguistic variation include both the set of recursive operations employed by the FLN, and the particular surface forms that are

handled by the FLN (as opposed to the lexicon) in a given language. For the child, an especially reliable source of evidence about language-particular properties of the FLN will be examples of recursion in the linguistic input. The strongest hypothesis, then, is that the inventory of recursive operations is the sole point of parameterization within the FLN, and that evidence of recursive application of these operations is what drives children's acquisition of syntax.

Notes

* We are grateful to Bob Berwick, Anna Maria Di Sciullo, Sonja Eisenbeiss, Sandiway Fong, Robbie Moll, and the audience at the 2002 Conference on Brain, Language, and Computation for stimulating discussion; and to Anders Holmberg and Anders Löfqvist, for the Swedish data in Section 2. Snyder's contributions were supported by NIH grant DCD-00183.

1. More recent work in the spirit of the Abstract Clitic Hypothesis includes Hale & Keyser (2002, Ch. 6) and van Hout & Roeper (1998).

2. In this paper we focus on "endocentric" compounds as in (1), where one part of the compound is clearly the head. We will set aside "exocentric" compounds such as French *essui-glace* 'windshield wiper' (lit. 'wipe(s)-windshield'). The latter forms are treated by Di Sciullo & Williams (1987) as a VP located under an N, and are there classified as "syntactic words."

3. Here a word of caution is in order. Our precise claim is that "Germanic-style" resultatives and verb-particle constructions are available only in languages that freely permit the creation of endocentric root compounds. Ultimately, this generalization should be explained in terms of a point of parametric variation much more abstract than the surface constructions themselves. Thus, even to the extent that we can give an operational definition of "Germanic-style verb-particle constructions," for example, this is merely a rough diagnostic for the nature of the underlying grammar. Di Sciullo (1999, 2002) correctly observes that Italian sometimes permits constructions that resemble the Germanic resultative and verb-particle constructions, even though it disallows endocentric root compounding as a creative process. Yet, the underlying grammar of Italian clearly must be different, as illustrated by the following examples (provided by Andrea Calabrese, p.c.).

- (i) a. John has beaten the metal (flat).
b. Gianni ha battuto il metallo (*piatto).
- (ii) a. John has lifted the box (up).
b. Gianni ha alzato la scatola (*su).

Thus, while the relevant similarities of Italian to Germanic certainly merit investigation, the differences are also considerable, as expected under the present proposals.

4. For acquisitional evidence linking novel N-N compounds and resultatives, see Sugisaki & Isobe (2000).

5. For reasons of space, however, discussion of Keyser & Roeper's approach to complex predicates will be limited to brief remarks in Section 4.

6. The term *clitic*, like all central terms of grammar, is used in both descriptive and explanatory ways. Careful analysis leads to more refined concepts, and it is unsurprising that a given term cannot be defined adequately to cover all cases. The use of the word *clitic* in *Abstract Clitic Hypothesis* is intended to capture two notions: a) that the projection is less than a Maximal Projection, and b) that it involves lexical drift together with a verb. Thus *give up* is not a compositional result of combining *give* and *up* together. The use of the term means nothing beyond these claims. How far it can connect to other uses of *clitic* – to capture, say, the phonological behavior of pronouns in French – is left open. The two primary points, non-maximality and the lexical connection, are quite important and warrant the use of the term. Though one might invent another term, it does not seem useful.

7. Note that movement of the modifier to the left of the compound's head is taken here to be the result of an independent morphological property of English. In general, material inserted into the ACP can remain *in situ*.

8. The deletion of an *argument* trace would lead to a violation of Full Interpretation (or of the Theta Criterion, in earlier formulations), but the deletability of certain non-argument traces has been proposed, for example, in Lasnik & Saito (1984). In the present proposal, the deletion of non-argument traces from the ACP appears to be necessary to capture both the restrictive nature of the position – that it cannot be filled overtly twice – and the possibility of recursion (*re-re-read*, *over-reinvest*) for elements of the same category. On the other hand, Merce Coll-Alfonso (p.c.) has suggested to us that trace-deletion could be avoided, if the NP node that is created by leftward movement projects a new clitic position of its own, where an additional modifier can then be inserted. We will leave this as an intriguing direction for future research.

9. See Fu, Roeper, & Borer (2001) for extensive discussion and further derivational processes for nominalizations.

10. In present terms, the First Sister Principle (FSP) of Roeper & Siegel (1978) appears to be a general constraint on the rule of compound formation, because it applies both to modifiers inserted through the ACP, and to arguments in synthetic compounds, which undergo compounding from a non-ACP position. The FSP accounts for contrasts such as the following:

- (i) a. well-made
- b. *well-maker
- c. well-sung
- d. *well-singer

These facts illustrate both that adverbial modifiers *well* can undergo compounding, and that such modifiers must be immediately adjacent to the verb when compound-formation applies. Thus, in (ii), the direct object *boat* is immediately adjacent to *make*, and is the only element that can be compounded with *make*.

- (ii) make [boat] well \Rightarrow boat-maker/*well-maker

Yet, if the passive applies, the modifier can be treated as the first sister:

(iii) [The boat was] made well. \Rightarrow well-made

Note that there are interesting intricacies here. Implicit objects, unlike the passive's underlying objects, block compounding:

(iv) He behaves well. \Rightarrow *well-behaver

In (iv) there is an implicit reflexive present, and this appears to count as the V's first sister. In (iv), like (v), *well* cannot participate in compounding.

(v) He behaves himself well.

11. We tentatively treat the Swedish infix *-s-* as a lexical head, rather than a functional head, on the grounds that functional material is more typically excluded from compounds.

12. A novel proposal of this paper, and a departure from earlier work, is that the ACP is specifically a position for *modifiers*. Arguments, under this approach, must occupy a conventional complement position, rather than the ACP.

13. The alternative analysis, as in *pen [hold-er]*, does occur (at least in English), but it delivers a different reading:

- (i) a. truck-driver
- b. gypsy driver

In the synthetic compound (i.a), there continues to be a verb-object relation, where the verb *drive* directly dominates the object. In the root compound (i.b), however, the N *gypsy* functions as a modifier of the whole word *driver*. A related example is *silver holder*, which can mean, as a synthetic compound, 'thing that holds silver'; or as a root compound, 'holder made of silver'. In Roeper & Siegel (1978) it was pointed out that "apparent synthetic compounds" can be identified by whether the second element can occur by itself. For instance, we have (ii.a, b).

- (ii) a. type-setter
- b. *he is a setter

The *-er* in (ii.a, b) is possible only when an object has been incorporated into the verb. In contrast, *driver* in (i.b) is an independent word, and can combine with other N's through root compounding.

14. Agent/instrument nominals formed with *-er* in English are discussed in some detail in van Hout & Roeper (1998). The fine-grained semantics of the French nominals in *-eur* may be slightly different, but we leave this to future research.

15. Note also that the ACP is only *one* source of recursion, even in the languages that have it. In French, where the ACP is unavailable, recursion is nonetheless possible with derivational morphology, in exocentric compounds, and in phrasal syntax.

16. More precisely, we assume that the ACP provides a derivational point of insertion for the modifier, in a root compound; for the particle, in a separable-particle construction; and for null morphemes required in each of the English double-object dative, middle, and null-P constructions.

17. The effects of (12) should similarly be widespread. A direction of current research is a comparative study of complex predicates in English and Swedish. If the ACP in Swedish is never occupied by a branching constituent, then (for example) we expect that English forms such as (i) will be systematically absent:

- (i) John lifted the box [right up].

In English, the modified particle [*right up*] can be inserted into the ACP, although it is necessarily extraposed before spell-out (as discussed in Keyser & Roeper 1992). In Swedish such forms are predicted to be altogether impossible, although we have not yet checked them with our Swedish consultants.

18. See Gentile (2001) for preliminary evidence that children of 3.5 years understand that [*John's sister's picture*] is acceptable in English, and refers to a picture of John's sister, not of John. As discussed there, recursive possessives in the adult input are rare but do occur. Representative examples from transcript data are "[Donna's dog]'s name is Tramp" and "What's [the hopperoo's friend]'s name?"

References

- Bauer, L. (1978). *The Grammar of Nominal Compounding, with Special Reference to Danish, English, and French*. Odense: Odense University Press.
- Di Sciullo, A.-M. (1999). Verbal structures and variation. In E. Treviño & J. Lema (Eds.), *Semantic Issues in Romance Syntax (Current issues in Linguistic Theory, Vol. 173)* (pp. 39–57). Amsterdam: John Benjamins.
- Di Sciullo, A.-M. & Williams, E. (1987). *On the Definition of Word*. Cambridge, Mass.: The MIT Press.
- Di Sciullo, A.-M. (2002). Symmetry, antisymmetry and tractability. Paper delivered at the Second International Conference of the Federation on Natural Language Processing, *Language, Brain and Computation*. University of Venice. Italy.
- Fu, J., Roeper, T., & Borer, H. (2001). The VP within process nominals: Evidence from adverbs and the VP anaphor *do-so*. *Natural Language & Linguistic Theory*, 19, 549–582.
- Hale, K. & Keyser, S. J. (2002). *Prolegomenon to a Theory of Argument Structure*. Cambridge, Mass.: MIT Press.
- Hauser, M. D., Chomsky, N., & Fitch, W. T. (2002). The faculty of language: What is it, who has it, and how did it evolve? *Science*, 298, 1569–1579.
- Keyser, S. J. & Roeper, T. (1992). Re: The abstract clitic hypothesis. *Linguistic Inquiry*, 23, 89–125.
- Lasnik, H. & Saito, M. (1984). On the nature of proper government. *Linguistic Inquiry*, 15, 235–289.
- MacWhinney, B. (2000). *The CHILDES Project: Tools for Analyzing Talk*. Mahwah, New Jersey: Lawrence Erlbaum Associates.
- Namiki, T. (1994). Subheads of compounds. In S. Chiba (Ed.), *Synchronic and Diachronic Approaches to Language: A Festschrift for Toshio Nakao on the Occasion of his Sixtieth Birthday* (pp. 269–285). Tokyo: Liber Press.

- Roeper, T. & Siegel, M. (1978). A lexical transformation for verbal compounds. *Linguistic Inquiry*, 9, 199–260.
- Roeper, T., Snyder, W., & Hiramatsu, K. (2002). Learnability in a Minimalist framework: Root compounds, merger, and the syntax-morphology interface. In I. Lasser (Ed.), *The Process of Language Acquisition*. Frankfurt: Peter Lang Verlag.
- Snyder, W. (1995). Language acquisition and language variation: The role of morphology. Ph.D. Dissertation, MIT.
- Snyder, W. (2001). On the nature of syntactic variation: Evidence from complex predicates and complex word-formation. *Language*, 77, 324–342.
- Sugisaki, K. & Isobe, M. (2000). Resultatives result from the compounding parameter: On the acquisitional correlation between resultatives and N-N compounds in Japanese. In R. Billerey & B. D. Lillehaugen (Eds.), *Proceedings of WCCFL XIX* (pp. 493–506). Somerville, Mass.: Cascadilla Press.
- van Hout, A. & Roeper, T. (1998). Events and aspectual structure in derivational morphology. *MIT Working Papers in Linguistics*, 32, 175–220.¹⁸